



HERASAFE 2025

Safety cabinets

Operating instructions

50161258

October, 31st 2019

Copyright 2019

These operating instructions are protected by copyright. Rights resulting thereof, particularly reprint, photomechanical or digital postprocessing or reproduction, even in part, are only allowed with the written consent of Thermo Electron LED GmbH. This regulation does not apply to reproductions for in-plant use.

Trademarks

Thermo Scientific is a brand of Thermo Fisher Scientific. All other trademarks mentioned in the operating instructions are the exclusive property of the respective manufacturers.

Thermo Electron LED GmbH
Robert-Bosch-Straße 1
D - 63505 Langenselbold
Germany

Thermo Electron LED GmbH is a subsidiary company of:
Thermo Fisher Scientific Inc.
168 Third Avenue
Waltham, MA 02451
USA

Table of Contents

Chapter 1 Table of Contents	3
Chapter 1 Figures	7
Chapter 1 General Notes	9
General Safety Instructions	10
Warranty	10
Explanation of Symbols	11
Symbols used in the Operating Instructions	11
Symbols on the Device	11
Use of the Device.....	13
Correct Use	13
Incorrect Use	13
Standards and Safety Regulations.....	14
Chapter 2 Delivery	15
Items supplied	15
Acceptance Inspection	15
Transport Lock and Device Packaging.....	15
Chapter 3 Installation of the Device	17
Ambient Conditions.....	17
Room Ventilation.....	18
Correct Location	18
Installation in Series.....	18
Connections	19
Power Receptacles	19
Transport	20
Chapter 4 Unit Description	21
Overall View	21
Safety System	22
Filter System	24
Controls and Display	25
Sample Chamber Access	26
Device Interfaces	28
UV Lamp Unit	30
Working Area	31
Chapter 5 Start-up	33
Initial Operation	33
Installing Unit and Accessories	33
Leveling the Device.....	35
Power Supply Connection.....	36
USB-Port.....	36
Installation Test	37

Chapter 6 Operation	39
Display.....	39
Explanation of the Display Components	39
Display in OFF-Mode	40
Display in Work-Mode	40
Power Interruption	40
Display and Functions after a Power Failure	40
Failure Messages	40
Description of the Operating Modes	41
Operation	43
Moving the Front Window into Working Position	44
Audible Warn Signal	45
Switching the Illumination ON and OFF	45
Activating/Deactivating Internal Power Supply	45
Changing UV-Disinfection Time	45
Switching the Cabinet to OFF-Mode	46
Setting Time	46
Display Operating Hours Air Inflow	47
Display Air Inlet Velocity	47
Display Downflow Velocity	47
Setting UV-Disinfection Time	48
Start UV-Disinfection	49
Cancel UV-Disinfection	49
Rocker Switch	49
Moving the Front Window	50
Chapter 7 Preparation	51
Hygiene Preparations for the Sample Chamber	51
Preparing the Sample Chamber	51
Response to Failure Messages	52
Work Rules	52
Chapter 8 Shut-down	55
Interrupting an Operation	55
Shutting the Unit down.....	55
Chapter 9 Cleaning and Decontamination	57
Decontamination Procedure	57
Wipe/Spray Disinfection	57
UV Disinfection after a Wipe/Spray Disinfection.....	59
UV Disinfection using the integral UV Lamps	59
Changing the UV Disinfection Time	59
Disinfection with Formaldehyde	59
Cleaning the exterior Surfaces	60
Cleaning the Front Window	60
Cleaning the Drain Pan	60
Replacing the inlet air protection.....	61

Chapter 10 Maintenance	63
Inspection	63
Service	63
UV Lamps	63
Sample Chamber Illumination	64
Replacing the Front Cover Seal	64
Retrofitting and Repairs.....	64
Chapter 11 Disposal	65
Disposal Procedure.....	65
Chapter 12 Technical Data	67
Chapter 13 Device Log	73
Chapter 14 Certificate of Decontamination	75

Figures

Figure 1 Correct Location.....	18
Figure 2 Lift Points	20
Figure 3 Overall View, Herasafe 2030i version	21
Figure 4 Filter System with Downflow Filter and Exhaust Air Filter.....	24
Figure 5 Controls and Display.....	25
Figure 6 Access through Front Cover	26
Figure 7 Access through Front Window.....	27
Figure 8 Supply Interfaces	28
Figure 9 Workspace Illumination.....	29
Figure 10 UV Lamp Unit.....	30
Figure 11 Working Area on the Workplate, Armrests.....	31
Figure 12 Stand Installation.....	34
Figure 13 USB-Port	36
Figure 14 Explanation of the Display components.....	39
Figure 15 Rocker switch	49
Figure 16 Sitting Posture	53
Figure 17 Inlet air protection	61

General Notes

The following are the addresses of the international Thermo Sales Organisations.

Postal address Germany

Thermo Electron LED GmbH
Robert-Bosch-Straße 1
D - 63505 Langenselbold

Enquiries from Germany

Phone

Sales 0800 1 536376
Service 0800 1 112110

Fax

Sales/Service 0800 1 112114

E-Mail

info.labequipment.de@thermofisher.com

Enquiries from Europe, Middle East and Africa

Tel. + 49 (0) 6184 / 90-6940
Fax + 49 (0) 6184 / 90-7474

Enquiries from North America:

Phone +1 800-879 7767 +1 800-879 7767
Fax +1 828-658 0363

Enquiries from Latin America:

Phone +1 828-658 2711
Fax +1 828-645 9466

Enquiries from Asia Pacific:

Phone +852-2711 3910
Fax +852-2711 3858

E-Mail

info.labequipment@thermofisher.com

General Safety Instructions

These safety instructions describe the safety features of the Herasafe 2025 series. The safety cabinet has been manufactured in keeping with the latest technological developments and has been tested before delivery for its correct function. It may, however, present potential hazards if it is not used according to the intended purpose or outside of operating parameters. Therefore, the following procedures must always be observed:

- The safety cabinet must be operated only by trained and authorized personnel.
- For any operation of this unit, the operator must prepare clear and concise written instructions in the language of the operating and cleaning personnel based on these operating instructions, applicable safety data sheets, plant hygiene guidelines, and technical regulations, in particular:
 - which decontamination measures are to be applied for the cabinet and accessories,
 - which protective measures apply while specific agents are used,
 - which measures are to be taken in the case of an accident.
- Repairs to the device must be carried out only by trained and authorized expert personnel.
- The contents of the operating instructions are subject to change without further notice.
- Concerning translations into foreign languages, the German version of these operating instructions is binding.
- Keep these operating instructions close to the unit so that safety instructions and important information are always accessible.
- Should you encounter problems that are not detailed adequately in these operating instructions, please contact Thermo Electron LED immediately for your own safety.



Impairment of the system may lead to hazards.

Warranty

Thermo Electron LED warrant the operational safety and functions of the safety cabinet only under the condition that:

- the device is operated and serviced exclusively in accordance with its intended purpose and as described in these operating instructions,
- the device is not modified,
- only original spare parts and accessories that have been approved by Thermo Electron LED are used,
- inspections and maintenance are performed at the specified intervals,
- an installation test is performed prior to the initial operation of the device and that a repeat test is performed on the occasion of all inspections and repairs.

The warranty is valid from the date of delivery of the device to the operator.

Explanation of Symbols

Symbols used in the Operating Instructions



Is used if non-observance may cause serious or even lethal injuries.



Is used if non-observance may cause medium to minor injuries or damage.

NOTE

is used for hints and useful information.



Valuable raw materials can be reused.

Symbols on the Device

Observe operating instructions



Biohazard



USB interface

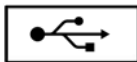

CE conformity mark: confirms conformity according to EU Directives



GS sign TÜV Nord



Filter replacement



2 x T5A outlet fusing (at mainboard)



2 x T 15 AH (at mainboard)



2 x T 16 AH Equipment Fusing (inside the electronic module)

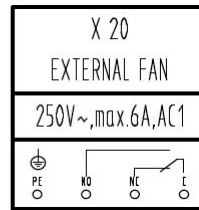
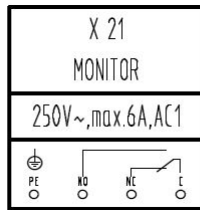
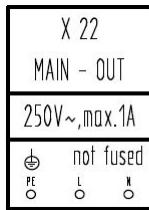

X20 connection for an external fan
 X21 connection for a solenoid valve
 X22 connection for an external component

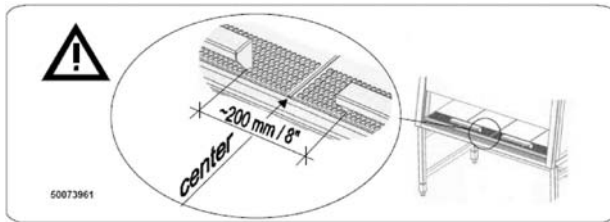

Armrest installation



UV lamp

EXHAUST*
 CAUTION-DECONTAMINATE*
 CABINET-BEFORE-OPENING*

SUPPLY*
 CAUTION-DECONTAMINATE*
 CABINET-BEFORE-OPENING*

At the supply lines for measurement of the raw air concentration by leakage testing of the filter.

Use of the Device

Correct Use

Herasafe 2025:

The safety cabinet is a laboratory device for installation and operation in microbiological and biotechnical laboratories of safety levels 1, 2, and 3. It has been designed as a Class II microbiological safety cabinet, in accordance with EN 12469:2000.

Depending on the hazard level of the agents involved, the operator must prepare in writing appropriate decontamination procedures for the device and the accessories used in the sample chamber.

Following media should be used:

- Vacuum (Rough vacuum 10 E-2 bar / 0,145 psi)
- Combustible gas (e.g. Propane)
- Non-combustible gas (e.g. Nitrogen)

Incorrect Use

The safety cabinet must not be used in laboratories that do not comply with the requirements of safety levels 1, 2, and 3.

The unit must not be operated as a Class II safety cabinet if:

- no repeat test is performed after changes to the installation conditions or after modifications to the technical system.
- the alarm system of the device has issued a failure message and the cause for the failure has not been repaired.

The alarm system must not be tampered with or disabled. If alarm system components have been removed or disabled for service or repairs, the unit must only be released for operation if all alarm system components are functioning again properly.

The filters installed in the device are not capable of separating gaseous substances.

Therefore, do not work with or store substances in the device:

- are toxic which in quantity or concentration,
- if a reaction with other substances may result in hazardous toxic concentrations or formation of toxic gases,
- that may form combustible or explosive mixtures in combination with air.

Standards and Safety Regulations

The device complies with the safety requirements of the following standards and guidelines:

- IEC 61010-1:2010 / EN 61010-1:2010
- EN 12469:2000
- EN 61326-1:2018
- Low Voltage Directive 2014/35/EU
- EMC Directive 2014/30/EU
- RoHS directive 2011/65/EU
- WEEE directive 2012/19/EU
- China EEP Hazardous Substances Information
<http://www.thermofisher.com/us/en/home/technical-resources/rohs-certificates.html>

Delivery

Items supplied

Delivery for the safety cabinet includes the following:

Herasafe 2025 version:

- safety cabinet
- armrests
- device documentation with:
 - operating instructions (CD)
 - factory test report
 - summarized safety instructions (SSI)
 - HEPA filter certificate

Optional components and accessories are listed as separate items in the delivery document.

Acceptance Inspection

After the device has been delivered, immediately check the device:

- for completeness,
- for possible damage.

If the delivery is incomplete or if you detect any transport damage to the device, contact the forwarding agency and Thermo Electron LED immediately.

Transport Lock and Device Packaging

Do not transport the device over large distances without transport lock and original device packaging.

Installation of the Device

Ambient Conditions

The operational safety and correct function of the unit depend on the location where it is to be operated. The safety cabinet must be operated only at locations that meet the ambient conditions listed below.

Location requirements:

- The electrical system of the device has been designed for an operating height of up to 2.000 m above sea level.
- The mains power supply outlets should be out of casual reach to prevent accidental shut-off. Ideally, the outlets should be installed above the safety cabinet and be readily accessible.
- The flooring of the location must be adequately strong and not flammable.
- The support frame must be designed with an adequate load-carrying capacity (supporting four times the weight of the device).
- The room in which the device is installed must be of adequate height. For units not connected to an exhaust system, the distance between the exhaust air opening and the room ceiling must be at least 200 mm. There is potential to install with a lower clearance of 200mm. This should be discussed with a Thermo Fisher Scientific BSC specialist.
- The location must be equipped with an appropriate ventilation system, see “Room Ventilation” on page 18.
- The temperature within the room must be between 10 °C and 40 °C.
- The power supply voltage should not vary by $\pm 10\%$ from its nominal value.
- Transient overvoltage peaks shall not exceed the usual range prevailing within the AC power supply grid. The nominal transient overvoltage level shall be the surge withstand voltage according to overvoltage category II of IEC 60364-4-443.
- An appropriate ground fault circuit interrupter must be installed by the customer to protect the device system.
- Condensation must be avoided, for example, subsequent to relocation or transport. Should condensation exist, wait for the humidity to evaporate completely before connecting to a power source or powering up the device.
- The relative humidity in the vicinity of the device must not exceed 90 %.

NOTE Ambient conditions

If ambient conditions vary from those described above, please contact Thermo Electron LED for assistance in installing the device.

NOTE Temporary storage

If the device is stored only temporarily (up to four weeks), the ambient temperature may be between -20 °C and +60 °C (-4 °F and +140 °F) at a relative air humidity of up to 90 %. For longer storage periods, the location requirements apply.

Room Ventilation

The room ventilation should preferably be a ventilation system that complies with the national requirements for the application.

- The inlet air and exhaust air openings of the room ventilation must be located so that drafts are prevented from impairing the function of the safety cabinet air system.

Correct Location

Choose a draft-free location where the safety cabinet does not interfere with the plant traffic.

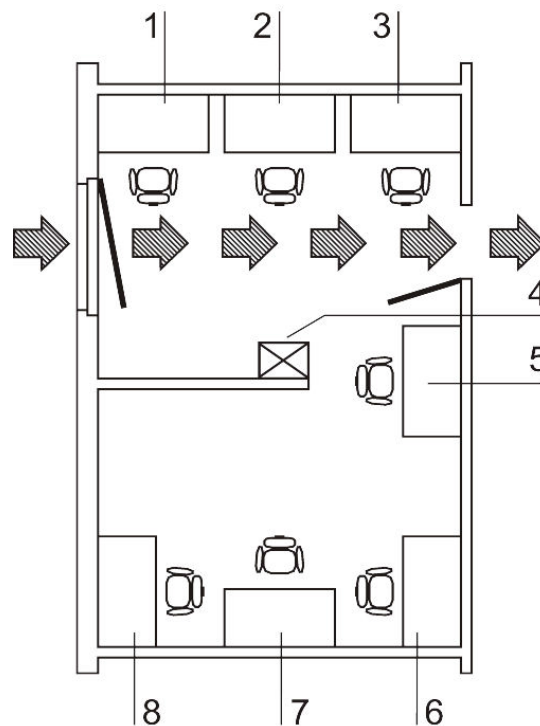

Figure 1 Correct Location

This figure shows preferred locations for safety cabinets and unsuitable locations, not in accordance with the safety requirements.

Unsuitable locations: The locations [1], [2] and [3] are not suitable because they are exposed to drafts from windows and doors.

Location [5] is undesirable because it is in range of plant traffic and within the exhaust air range of a ventilation system [4].

Preferred locations: Preferred locations [6], [7], and [8] are correct because they are in a draft-free section of the room and not exposed to plant traffic.

Installation in Series

When several devices are to be installed in series, please observe the following:

- Make sure that vibrations cannot be transferred between adjacent units,
- exterior surfaces of the cabinets must always be accessible for cleaning and disinfection,
- minimum distance of 2 m (6.6 ft.) between workbenches on opposite position.

Connections

Power cable



X22 X21 X20



High voltage

Before starting any work on electrical and electronic components, the unit must be disconnected from the power supply. The work may only be carried out by an electrically qualified person.

Cable glands allow for connecting up to 3 external devices.

Connect directly to the printed circuit board!

Caution! Make sure the max. current output is not exceeded!

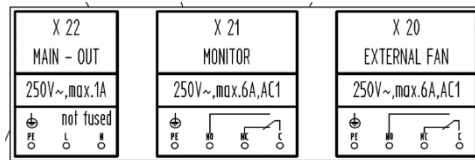

X22 230V Power Supply / X21 Monitor Alarm / X20 External Fan

The leads can be attached on the outer face of the anti-tilt anchor using cable ties.

Power Receptacles



The power receptacles are fused using a T 5A slow-blow fuse.

Transport

Herasafe 2025:

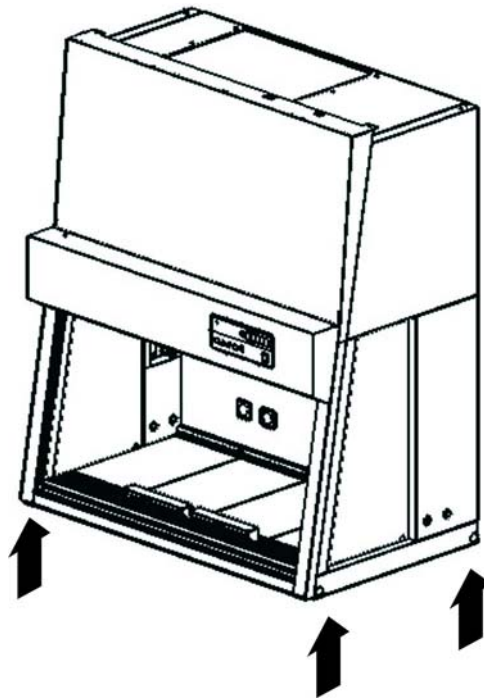

Figure 2 Lift Points

To prevent tilting, always transport the device using a suitable carrier, even for a transport within a building, and separate it from the stand.



Danger of tipping over!

For transport, lift the device only using the lift points shown in the illustration.
Do not load the drain pan with the weight of the device frame!



Contusion hazard!

When lifting the safety cabinet, do not put hands or fingers between drain pan and frame!

Unit Description

Overall View

Herasafe 2025:

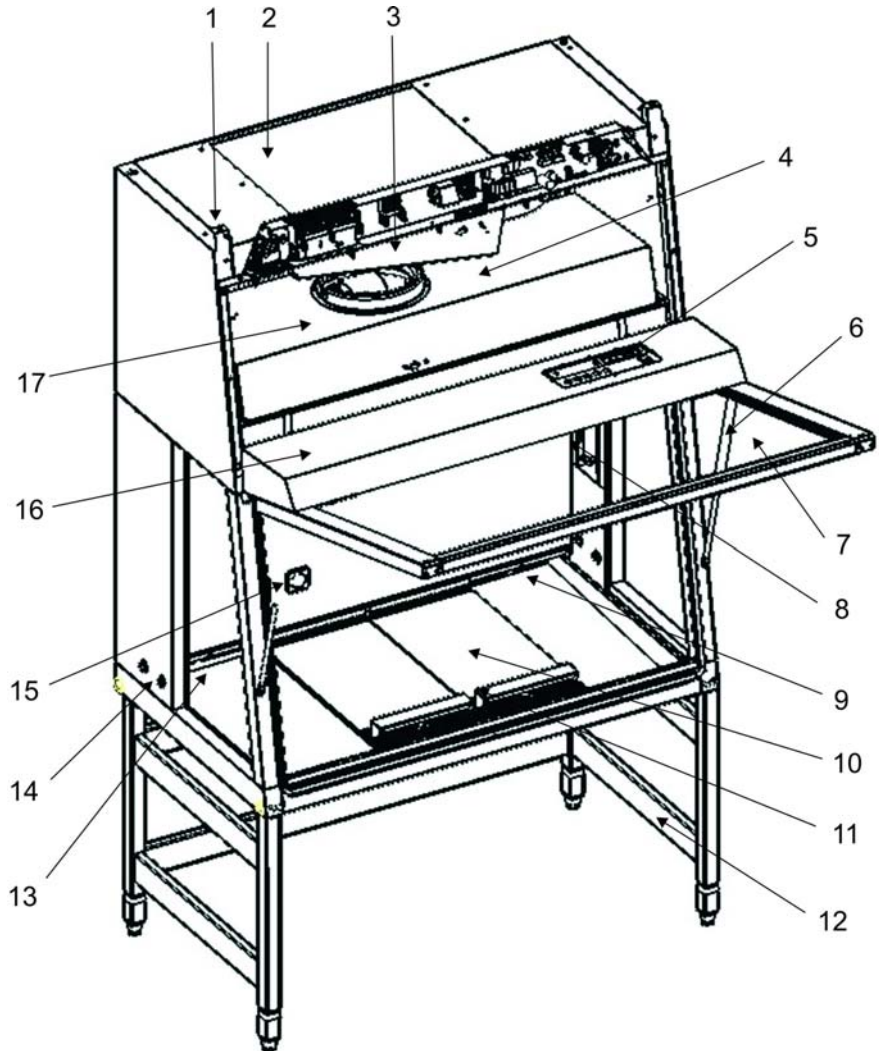

Figure 3 Overall View, Herasafe 2030i version

- Power supply cable [1].
- Plenum assembly with plenum for downflow blower [4] and plenum for exhaust air blower [3]. The downflow filter and the exhaust air filter are installed directly to the pertaining blower. The exhaust air is released into the environment around the device through the opening [2].
- Operating panel with cabinet controls, alarm system displays and cabinet status display. An auxiliary rocker switch for basic BSC window operation is located at the right side in the display area.
- The gas struts [6] secure the front cover in the open state.
- Front cover with integral, electrically movable front window [7].
- Optional UV lamp unit [8] consisting of two UV lamps per side.

- Test hoses for the exhaust air unit [9] and the downflow unit [13] are under the work plates.
- Optional stands [12], adjustable in height and with fixed height.
- Side slates with two sealed access openings [14]. These can be equipped with media valves.
- Internal outlets [15] for power supply of accessories.
- Lighting device [16], equipped with 2 tubes, is mounted on the front window.
- Workplate segments [10] with arm rests [11]. A one-piece workplate and special work plates are available options..

NOTE Test hoses

Do not remove the two test hoses for checking downflow and exhaust air.

Safety System

The safety system comprises a combination of protective and alarm systems that ensure maximum personal and material protection.

Safety systems:

- **Vacuum-sealed air system**

An air system in combination with HEPA filters for downflow and exhaust air forms the basis of the safety system for personal and material protection.

- **Personal protection**

Air aspirated from the exterior along the entire working opening at a constant high speed prevents that:

- agents may leak through the working opening of the chamber.

As the exterior air pressure around the unit exceeds the pressure of the internal air system, it is ensured that:

- agents cannot be released to the exterior in the case of a leak in the cabinet housing.

- **Product protection**

A steady airflow within the air system ensures that:

- a constant downflow allows the HEPA filters to remove contaminants so that the samples are always surrounded by ultrapure air,
- harmful particles are not carried over through the sample chamber (protection from cross-contamination).

- **HEPA filters**

The downflow (i.e. the air circulating within the device) and the exhaust air (air that is released to the exterior) are cleaned by HEPA filters (HEPA = High Efficiency Particulate Air Filter).

- **Safety lockout**

To protect from UV radiation, the optional UV disinfection routine can be run only if the front opening is closed. During UV disinfection, the front opening safety lockout is activated and prevents harmful UV radiation from being emitted from the sample chamber.

Warning system:

- **Airflow monitoring**

Airflow monitoring determines the speed of the airflow in the sample chamber as well as the inflow speed of the air aspired from the exterior through the working opening. As soon as air speeds move above or below a specified safety value, a signal is transmitted to the alarm system.

- **Visual and audible alarm system**

The warning system constantly monitors the safety-relevant device functions:

- inflow speed of the air aspired from the exterior,
- downflow speed,
- working position of the front window.

If the warning system detects changes to one of these device functions, it issues:

- an audible and a visual alarm signal.

- **Position monitoring**

The position sensors monitor the position of the front window; it will indicate when the front window is in the working position.

Filter System

HeraSafe 2025

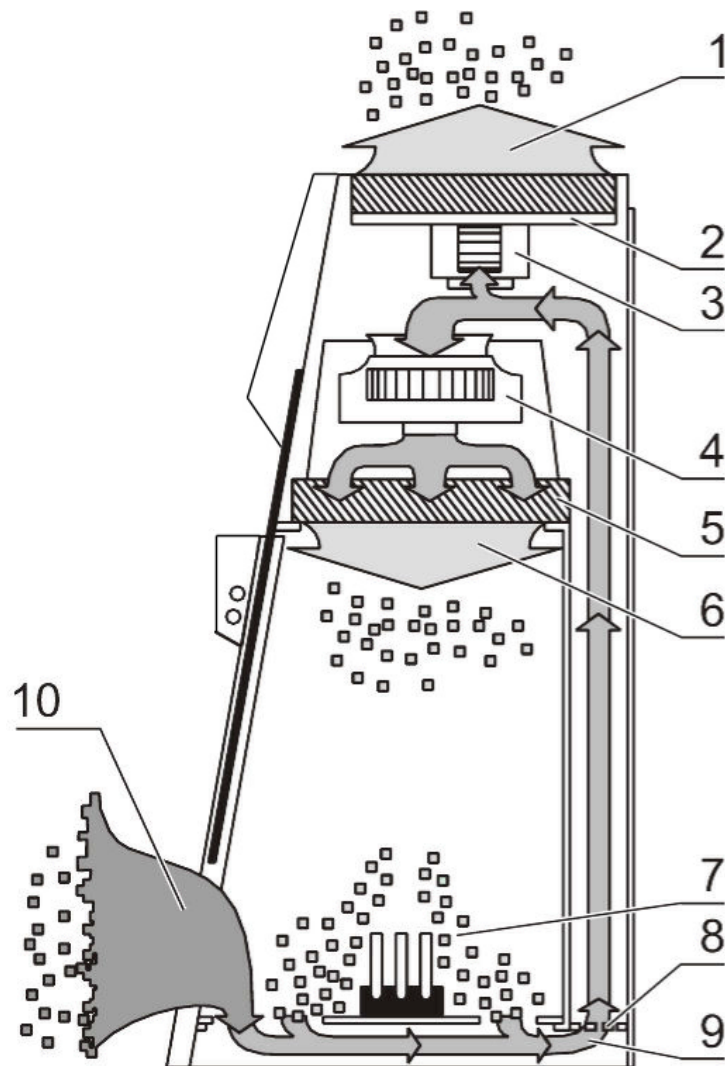

Figure 4 Filter System with Downflow Filter and Exhaust Air Filter

The filter system consists of two HEPA filters [2] and [5] for the circulating air and for the exhaust air and a coarse filter for the aspirated air.

HEPA filters: Room air [10] is drawn into the sample chamber through the working opening. In the air duct, room air and the downflow within the chamber [7] are then blended to make up the blend air [9]. The blend air is then:

- filtered proportionally by the downflow filter [5] and supplied as ultrapure air [6] evenly into the sample chamber of the device,
- filtered by the exhaust air filter [2] and released as ultrapure air [1] to the exterior of the device.

Inlet air protection: The air duct between the sample chamber and the device plenum has an inlet air protection [8] below the working surface to prevent coarse particles from entering the plenum where they may impair blower [3] and [4] and filter functions.

Controls and Display

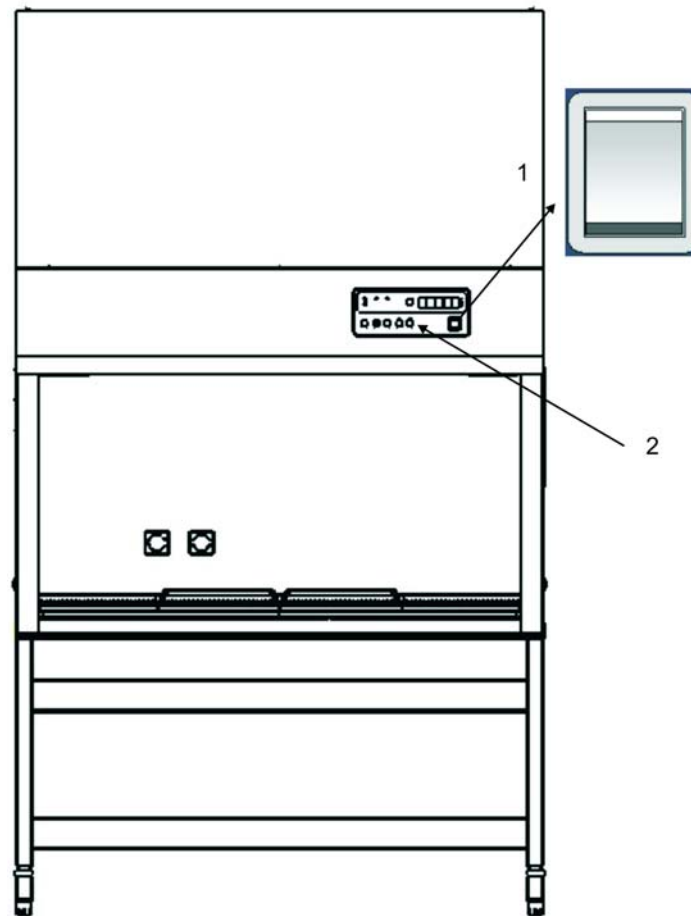

Figure 5 Controls and Display

The safety cabinet is equipped with two separate control elements that operate independently of each other:

- Rocker switch [1] to move the front window up and down
- Foil keypad to control the equipment functions [2].

The status indicators of the display [2] indicate control operations initiated with the control elements.

In the foil keypad the current status of the cabinet is shown.

Sample Chamber Access

The sample chamber of the device is accessible via two modes.

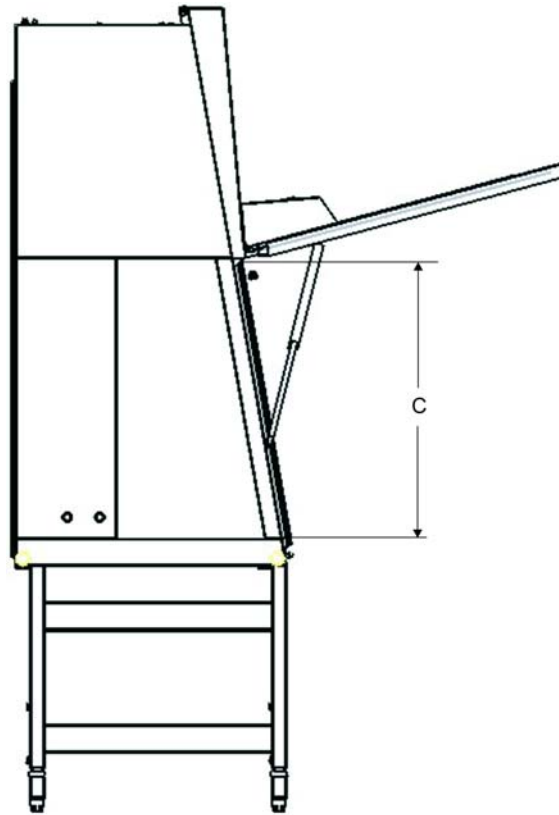

Figure 6 Access through Front Cover

Front cover:

Manual opening of the front cover [1] allows access to the complete sample chamber width with an opening height C. It is generally needed for decontamination and introduction of larger accessories.

NOTE Front cover lockout

The front cover is equipped with a safety lockout and can only be open when the front window is completely closed.

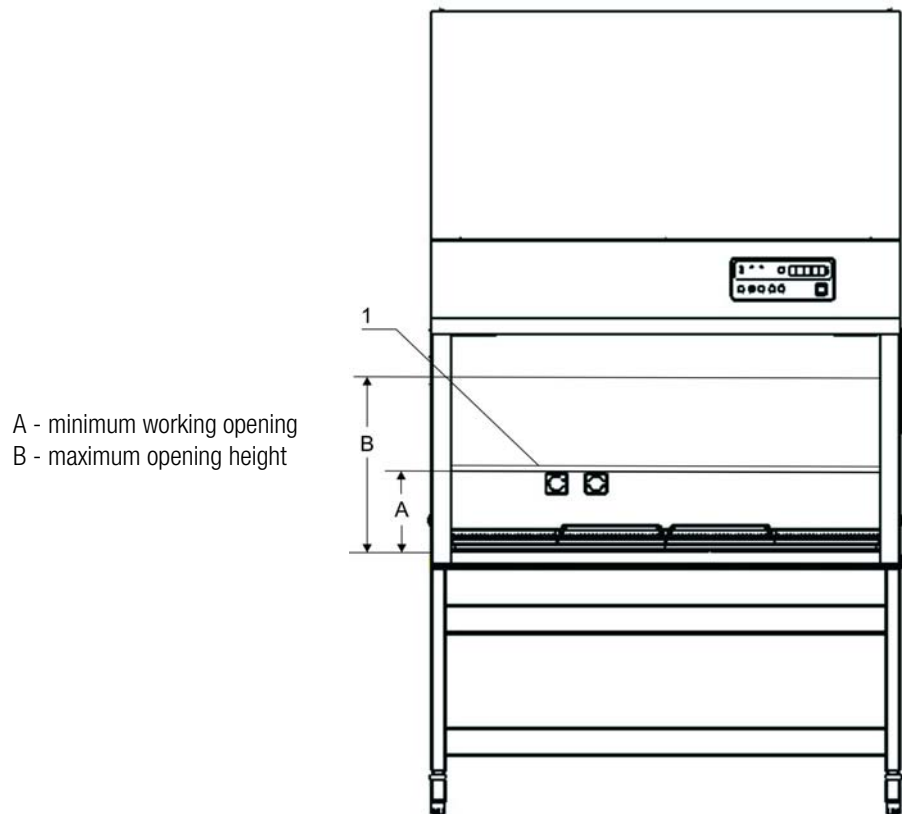

A - minimum working opening
B - maximum opening height

Figure 7 Access through Front Window

Front window:

The electrically operated front window [1] is made of multi-layer safety glass and integral to the front cover frame. It can be raised to a maximum opening height B. To access the sample chamber during the work process, the front window must stay in the work position with opening height A.



Crushing hazard

During movement of the front window do not try to access the inner chamber.



Front window movement!

Do not attempt to move the front window manually as otherwise the motor drive may be damaged.

Lowering the front window when the device is deenergized:

The safety feature is backed up by a battery. Should a power failure occur, the auxiliary rocker switch (see "Using the auxiliary Rocker Switch" on page 52) can be used to lower the front window completely.

Device Interfaces

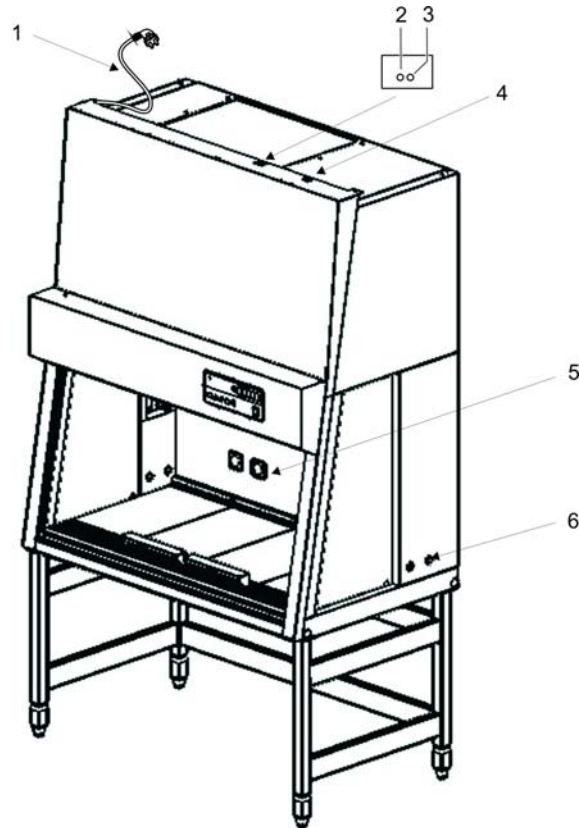

Figure 8 Supply Interfaces

Power supply connection: The connection to the power supply system is achieved through a cable with grounding plug [1] at the upper side.

Contact: Two fuse holders for 5A miniature fuses are located at the top rear of the cabinet [2] for L-Phase, [3] for N-Neutral. The USB interface [4] is installed for service.

The standard equipment includes the sockets [5] for the internal power supply and the two-sided feedthroughs [6] for cables and hoses.

NOTE

The connection of the piping and media valves has to be carried out according to country specific standards and by expert personnel only.



Combustible gas!

The use of a gas burner is not recommended.

If a gas burner is to be operated in the sample chamber, then a low profile burner should be used and an appropriate shut-off device for the gas supply system (shut-off valve, solenoid valve) must be installed.

Use only laboratory safety burners in the sample chamber.

External systems: Failure detection systems or gas supply solenoid valves may be connected to the safety cabinet control.

Workspace Illumination

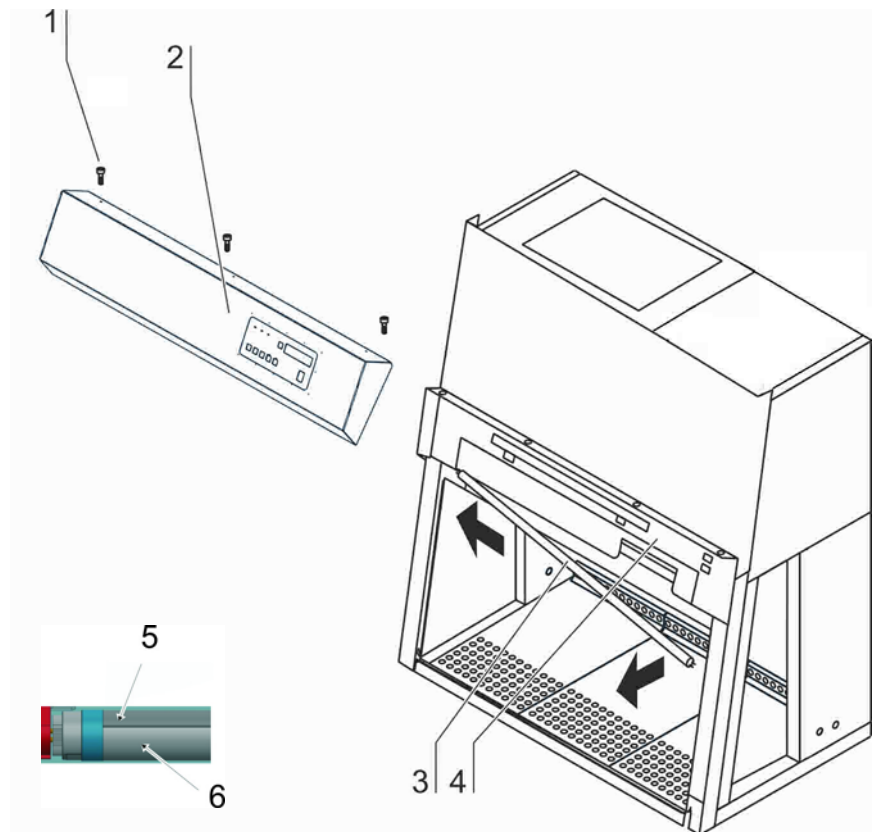

Figure 9 Workspace Illumination

The workspace illumination [2], with fixing screws [1] is equipped with two LED [3] that are installed behind the light dome [4].

NOTE

The reflector side (5) must be installed upwards, so that the radiation side (6) is fully active.

UV Lamp Unit

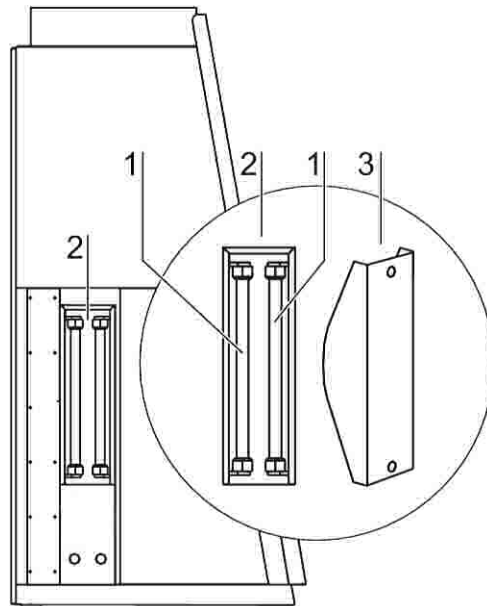

Figure 10 UV Lamp Unit

The UV lamp unit consists of two lamp housings [2] with two UV lamps each [1] that are integral to the side walls. Both lamp housings are protected by a stainless steel cover [3].

By cross-radiation of the UV units, all surfaces will be disinfected as the shadow zone is reduced. The operating time of the UV lamps is preset and can be changed by the operator.

NOTE Protection from UV radiation

As a protection from harmful UV radiation, the UV lamps can only be activated if the front window is completely closed.

Working Area

The standard equipment comprises the segmented workplate for the Herasafe 2025. Special workplates are available as optional accessories. The workplates or workplate segments are placed onto the frame above the workspace drain pan.

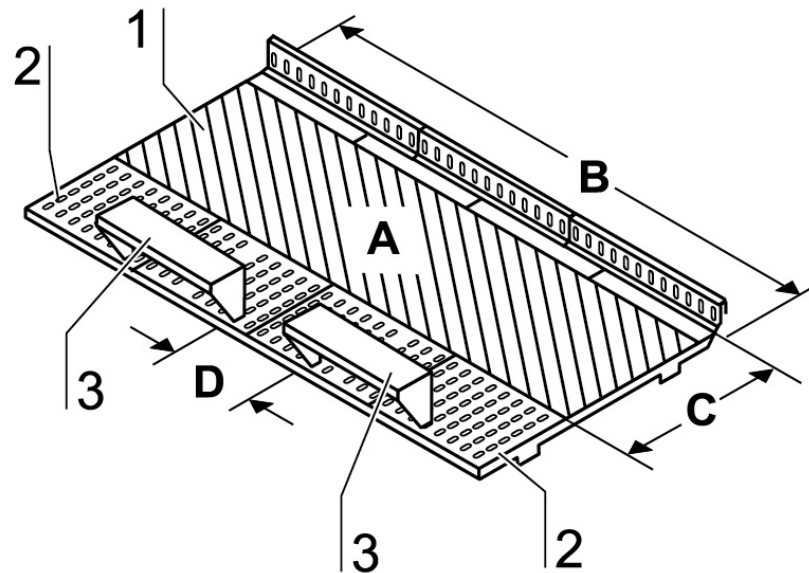

Figure 11 Working Area on the Workplate, Armrests

The working area A for perfect material protection extends over the entire width B and depth C of the workplate [1]. The two arm rests [3] are positioned at a distance D (20 cm) to each other centrally on the workplate [1] or on the workplate segments. The armrests are installed to the second perforation line [2] of the workplate.



The 2 armrests (3) are safety relevant component parts!

Start-up

Initial Operation

Prior to initial operation, the safety cabinet must be subjected to an installation test. Correct assembly and installation performed by the operator are essential for good start-up.

Installing Unit and Accessories

Herasafe 2025:

Device without stand:

- Place the device without stand onto a sufficiently stable substructure so that the weight of the device frame does not rest upon the drain pan.
- Remove the protective foil from the table tops and arm rests.

Device with stand:

To assemble the (optional) stand and to install the device frame to the stand:

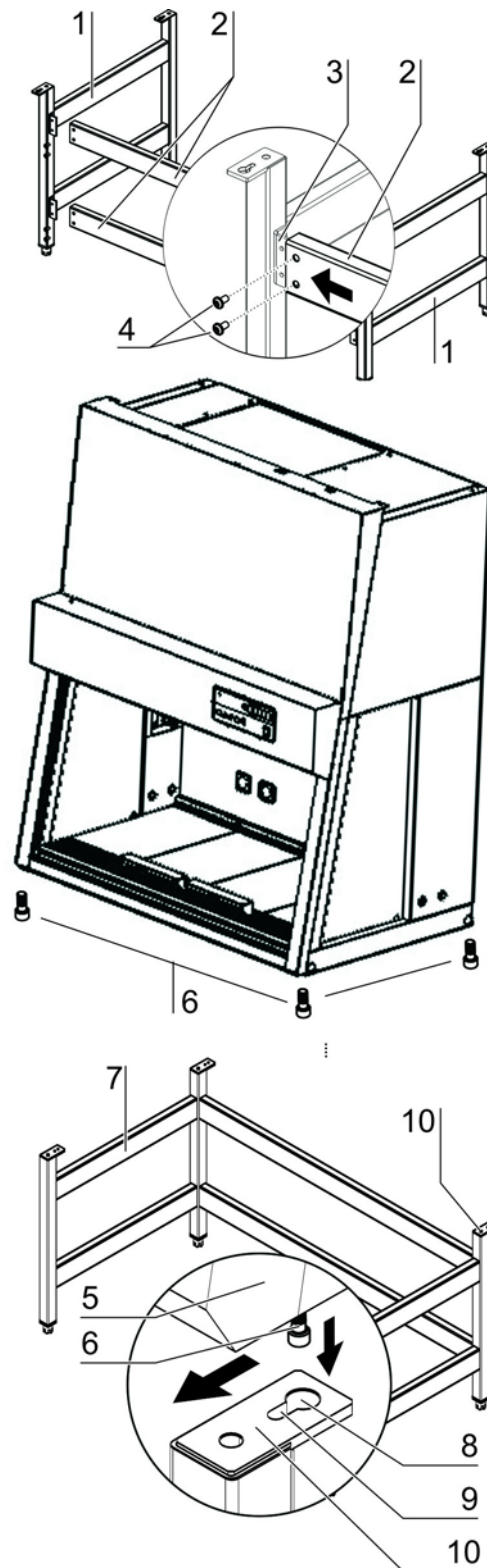

Figure 12 Stand Installation

1. Slide the two crossmembers [2] onto the retaining angles [3] of the sidemembers [1]. Secure the crossmembers to the two sidemembers using the screws [4].

2. To attach the device frame [5] to the stand [7], install four Allen screws [6] loosely into the corresponding threaded holes at the underside of the device.
3. Place the safety cabinet onto the stand so that the Allen screws [6] pass through the corresponding holes [8] of the retaining tabs [10].
4. Push the device frame [5] in the grooves [9] of the retaining tabs [10] all the way to the stop.
5. Tighten the four Allen screws [6].

Leveling the Device

The cabinet should be levelled only after it has been positioned.

1. Remove transport protection (foil) from the workplate or from the workplate segments.
2. Lift the workplate or the workplate segments and place it/them onto the front and rear rails in the sample chamber with the wide line of holes facing forward.
3. Device without stand: Place a bubble level onto the workplate and align the substructure until the bubble level indicates an exactly horizontal position in all directions.
4. Device with a stand: Place a bubble level onto the workplate and use the four levellers to effect a level state in all planes.
When adjusting the device stand height, proceed from right to left and from rear to front.

Power Supply Connection



High voltage!

Contact with current-carrying components may cause a lethal electric shock.

Before connecting the device to the power supply system, check plug and power supply cable for possible damage. Do not use damaged components to connect the device to the power supply system!

The connection has to be carried out according to country specific standards.

Establishing the power supply connection:

1. Before connecting the device to the power supply system, check to see if the voltage of the outlet corresponds with the specifications on the nameplate of the device. If the ratings given for voltage (V) and maximum current (A) are not correct, the device must not be connected to the power supply system.
2. Connect the grounding plug of the device to a properly grounded and fused outlet.
 - The outlet must be fused separately using a fusible link T 16 A or using a circuit breaker B 16.
3. Make sure that the power supply line is not subjected to tensile or compressive force.

Installation of the power supply connection:

To protect against accidental switch-off, the outlets for the connection to the power supply must be located outside the normal hand reaching range and must be accessible only to authorized personnel. Ideally, the outlets should be installed above the safety cabinet and be readily accessible. Route the power cables so they do not run across hot surfaces (such as exhaust tubing or similar tubing runs).

Connecting the equipotential bonding:

If the sample chamber is supplied with media (gas, water, etc.), the on-site equipotential bonding must be connected to one of the premounted threaded bushings at the top of the housing.

Initialization routine:

After the unit has been connected to the power supply system, the device control runs through a start-up initialization routine.

USB-Port

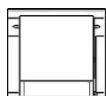

Figure 13 USB-Port

The USB-Port on the top of the device is reserved for service work!

Installation Test

Do not operate the device before the installation test has been completed.

- The installation inspection of the device must be conducted in accordance with EN 12469. The cabinet may be operated as a Class II microbiological safety cabinet, in accordance with EN 12469 / 2000, if the device functions or function patterns listed below were checked and if the test results are within the safety value tolerances specified by the manufacturer:
 - Electrical safety test
 - Inflow speed test
 - Downflow speed test
 - Leakage test of HEPA filters
 - Airflow control test
- A repeat test must also be performed after repairs to the device or after considerable changes (more than 5 cm) to the location of the device.
- The operator must prepare a test report or request a written test report from the authorized test service.

NOTE Safety warranty

The operational safety of the device, particularly the personal and material protection, are guaranteed only if all safety functions of the device have been tested and approved.

Thermo Electron LED will not warrant the operational safety if the device is operated without performance of the required installation test or if the installation test and repeat test are not performed by adequately trained and authorized personnel!

NOTE Device hygiene

The initial start-up with subsequent installation test does not include any decontamination measures. For operation in the work process, the sample chamber of the device and the accessories required for the work process must be disinfected and cleaned in accordance with the hygiene guidelines set forth for the application.

Operation

Display

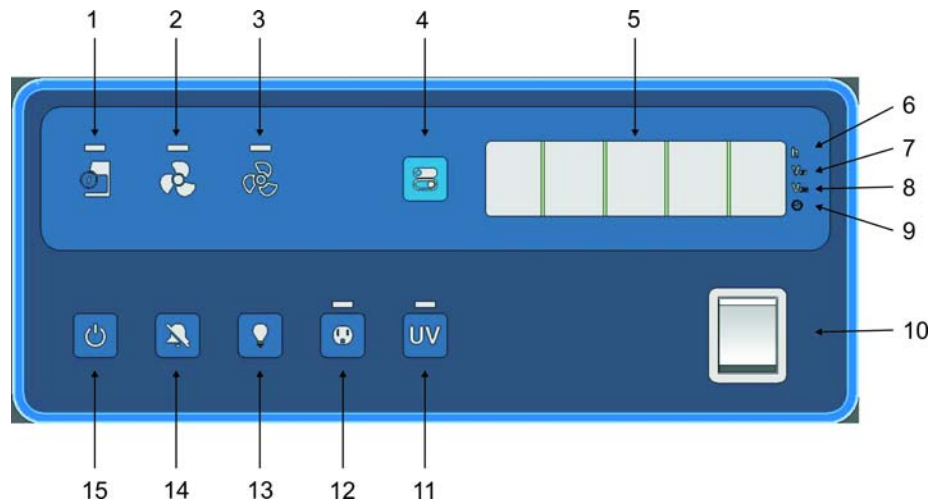

Figure 14 Explanation of the Display components

The display in the light dome is used as indicator and output instrument for:

- status messages
- parameter input and output

Explanation of the Display Components

- [1] Front window in (green LED) or outside (red LED) the working position.
- [2] Air velocity OK (green LED) or not OK (red) LED).
- [3] Ventilation reduced ON (blue LED)
- [4] Switch display switchover
- [5] Display 7-Segment
- [6] Total operating hours
- [7] Air inlet velocity
- [8] Downflow velocity
- [9] Time
- [10] Rocker switch
- [11] Switch UV disinfection on/off (the yellow LED indicates that the UV disinfection routine has been activated; if the optional UV lamp is not installed, the function of this key is disabled).
- [12] Switch internal sockets on/off, the blue LED indicates that voltage is applied
- [13] Switch cabinet illumination on/off
- [14] Acknowledge audible Alarm
- [15] Switch unit on/off (switch off in Stand-By-Mode only)

Display in OFF-Mode

In the OFF mode, the display shows the current time.

For the initial start-up of the device, the clock must be set to the correct time zone and to the corresponding time output (CET mode or AM/PM mode), (see Setting Time).

Display in Work-Mode

In the work mode, the display shows the values of the device data that had been shown last; (see Setting Time):

- Total operating hours
- Air inlet velocity
- Downflow velocity
- Time

Power Interruption

If the master PCB of the device detects a power failure or a failure of the power supply, a warning is issued..

NOTE Power failure warning

In case of a power failure, the display goes off after 10 seconds, then an audible alarm signal sounds for about 30 seconds. After this warning, the device is no longer operative.

The safety function allows the front window to be completely lowered by operating the rocker switch after a power failure.

Display and Functions after a Power Failure

After the power supply has been reestablished after a power failure, the display shows the values and functions that were last shown prior to the failure. The functions that had been selected last will be continued where they had been interrupted.

Failure Messages

Failure messages are shown on the display as text/number combinations with the codes ER 1 to ER 84. If one of these codes appears on the display, contact Technical Service immediately.

Table 1. Fehlermeldungen

Error code	Fault cause
ER 3	Pressure sensor 1 Downflow
ER 4	Pressure sensor 2 Exhaust air
ER 5	NVRAM - Error
ER 6	BUS - Error
ER 7	Switch error front window
ER 8	BUS - Error Add-on PCB

Table 1. Fehlermeldungen

Error code	Fault cause
ER 82	Current too high moving front window up
ER 83	Current too high moving front window down
ER 84	Fan speed faulty

Description of the Operating Modes

Following operating modes exists for the device:

- OFF-Mode
- Work-Mode
- Window-Open-Mode
- Stand-By-Mode
- UV-Mode

OFF-Mode: The device is at "idle". Utilized for charging the sample chamber or for cleaning and disinfection, the front cover can be opened when the front window is completely closed.

- The air system blowers are switched off.
- The sample chamber illumination is available.
The internal power supply within the sample chamber is available:
 - If the internal power supply is activated, the blue status indicator INTERNAL POWER SUPPLY ACTIVATED is illuminated.
- Time is shown at the display.
- The contact for the external device connection is not available.

Work-Mode: Ensures personal and material protection. In this operating mode, the work process is run within the sample chamber. The device is in the work mode when the front window has been moved into the working position and the airflow is steady.

- The front window is in the working position:
 - The green status indicator FRONT WINDOW IS IN WORKING POSITION is illuminated.
 - No audible alarm signal.
- The air system blowers are switched on to ensure steady airflow:
 - The green status indicator AIRFLOW STEADY is illuminated.
- The sample chamber illumination is available.
- The power supply for the sample chamber outlets is available:

- If the internal power supply is ON, the blue status indicator INTERNAL POWER SUPPLY ACTIVATED is illuminated.
- The monitor contact for the external device connection is ready for operation: The switching state of the potential-free contact is switched through (for example, if the solenoid valve of the gas supply line is activated via this contact, gas is supplied only in this mode).
- The display can show values for: Operating hours, downflow velocity, and exhaust airflow velocity or the time, according to the selection of the operator.

Window-Open-Mode: Designates the condition when the window is open and located outside the working position. To install and remove accessories, the front window can be opened or moved upwards.

- The airflow system blowers are switched on :
 - The red status indicator AIRFLOW NOT STEADY Is illuminated.
- The front window is not in the working position:
 - The red status indicator FRONT WINDOW NOT IN WORKING POSITION is illuminated.
- The work space illumination is operational.
- The audible alarm is active.
- The internal power supply is operational:
 - If the internal power supply is switched on, the status indicator INTERNAL POWER SUPPLY ACTIVATED illuminates.

Stand-By-Mode: For an interruption of the work process, the front window can be lowered and the sample chamber sealed aerosol-tight. The air system output has been reduced to match the lower air requirement.

- The front window is closed:
 - The air system operates at reduced output.
- The red status indicator FRONT WINDOW IS NOT IN WORKING POSITION is illuminated.
 - The blue status indicator AIRFLOW REDUCED is illuminated.
- The sample chamber illumination is available.
- The internal power supply in the sample chamber is available:
 - If the internal power supply is ON, the blue status indicator INTERNAL POWER SUPPLY ACTIVATED is illuminated.

UV-Mode: For running the UV disinfection routine, the front window is completely lowered to protect against UV radiation. The routine cannot be run until the front window is in the "closed" position.

- The UV-Disinfections routine is active:
 - The yellow status indicator UV DISINFECTION ROUTINE ACTIVATED is illuminated until the preset time for the routine has elapsed. Then, the UV lamps are switched off automatically, and the status indicator is switched off.
- The sample chamber illumination is available.
- The internal power supply in the sample chamber is not available.
- The integral UV lamp (optional) is available.
- The 7-segment display shows the remaining time until the complete UV routine has expired.



Operation

The device control software automatically determines the temporary operating state of the safety cabinet and automatically disables those functions of the operating panel that are in contradiction to the safety requirements of the switching state.

NOTE





The front window can only be moved with the rocker switch.

The easy operator guidance ensures that all basic functions can be controlled with only a few operating steps and that the safety cabinet can be shifted into the working mode.

- Switch device into work mode:
 - Keep the  key depressed until ready signal sounds.
- Moving the front window up:
 - Keep rocker switch depressed.
When the front window reaches the working position, the movement stops automatically. When the movement starts above the working position, the front window stops at the maximal opening position.
- Stopping the upward moving:
 - Release rocker switch.
- Lowering the front window:
 - Keep lower side of the rocker switch depressed.
- Stopping the downward moving:
 - Release rocker switch.
- Switching the device to OFF-Mode:
 - Keep the  key depressed until ready signal sounds.



Availability of functions in the different operating modes: x = available

Table 2.

Taste	OFF-Mode	Work-Mode	Stand-By-Mode	UV-Mode
	X		X	
Rocker switch up		X	X	X
Rocker switch down		X		
	X	X	X	
		X	X	X
	X	X	X	
		X	X ¹⁾	
Potential-free contact switches automatically.		(X)		

¹⁾ Time/Operating hours

Moving the Front Window into Working Position

1. Raising the front window:
 - Keep upper side of the rocker switch depressed.
 - The red status indicator  on the display is illuminated.
 - The audible alarm signal is on.
2. When the front window reaches the working position, the movement is automatically stopped.
 - The green status indicator  on the display is illuminated.
 - The audible alarm signal is off if the airflow is steady.
3. If the movement starts above the working position, the front window must first be lowered below the working position and then be raised again. To lower the front window:
 - Keep lower side of the rocker switch depressed.
4. Stop downward movement:
 - Release rocker switch.

Audible Warn Signal

When the front window is moved out of the working position or when the pressure sensors detect a safety-relevant change of the airflow velocities, the corresponding visual and audible alarm signals are issued. The alarm remains active until the front window has been moved to the correct working position or until the airflow velocity corresponds with the preset values.



Unsafe working!

When the alarm signals are activated, safe working is no longer ensured!

NOTE Switching the alarm signals off.

If the alarm signals fail to be switched off automatically, move the front window to the lowest position and contact the Technical Service.

Switching the Illumination ON and OFF

In each operating mode, excluded UV-disinfection, the sample chamber illumination can be switched on or off.

- Switching illumination on or off:

Shortly press key 

Activating/Deactivating Internal Power Supply

All sockets in the sample room are supplied with power in a switching operation or de-energized.

1. Switch on power supply:

Shortly press key 

The blue status indicator  is illuminated.

2. Switch off power supply:

Shortly press key 

The status indicator  goes off.

Changing UV-Desinfection Time

This value refers to the set run time of the UV disinfection (optional). This display function is only available when the front window is not closed. The device must be switched to work mode (see Setting UV-Disinfection).

Switching the Cabinet to OFF-Mode

The unit can be switched to OFF mode from any other operating mode:

- Move front window completely down
- Keep the key  depressed until ready signal sounds.

Setting Time

The current time of the time zone in which the unit operates must be set at the start-up of the safety cabinet. Two different display modes can be selected:

- CET-Mode (24:00 hours)
- AM- / PM-Mode (12:00 hours)

To set the time, the unit must be switched on and the front window must be outside the working position.

1. Setting time:

Keep the key  depressed, until the two-digit hour display flashes.

The minute display shows either A, P or no value (CET time display). The time zone is set at the same time as the hour value: First, set the time zone (sequence: CET, A, P), then set the exact hour value.

2. While increasing or decreasing the hour value in increments, set the time zone:

Shortly press key  or key  .

3. Scroll thru values:

Depress key  or key  .

If the keys are depressed for approx. 2 or 3 seconds, a higher scroll speed is selected.

4. Store the hour and time zone setting

Shortly press key  .

The function switches to minute display (flashing).

5. Setting the minutes:

Shortly press key  or key  .

6. Scroll thru values:

Depress key  or key  .

If the keys are depressed for approx. 2 or 3 seconds, a higher scroll speed is selected.

7. Store the minute value:

Shortly press key .

The time is shown at the display.

NOTE Calling up device data

The following data can be called up in succession:

- Total operating hours
- Air inflow velocity
- Downflow velocity
- Time

To call up values in succession:

- Press shortly key .

The following three sections contain detailed information about displaying values.

Display Operating Hours Air Inflow

With this function the operating hours can be displayed.

1. Display value total operating hours:



Press key  as often until LED  is white illuminated.

2. The value indicates the full hours.

Display Air Inlet Velocity

With this function the operating hours can be displayed.

1. Display value total operating hours:

Press key  as often until LED  is white illuminated.

2. The value indicates the air inlet velocity in meters per second.

Display Downflow Velocity

The device sensor system permanently monitors the circulating air velocity of the air flow in the sample chamber. The currently determined value (m/s) can only be called up in working mode.

- Display velocity value:

Press key  as often until LED  is white illuminated.

Setting UV-Disinfection Time

Depending on the equipment option of the cabinet, this setting is used to determine the disinfection time of the optional UV lamps.

Factory setting is one hour. The time can be set within a range between 0 and 24 hours in increments of 30 minutes each. The unit must be in the work mode (the front window must not be closed). For each following start of the UV disinfection, the routine is run with this preset time value.

1. Select the function:

Depress key  until ready signal sounds.

The display flashes the run time that had been selected last.

2. Set or change the disinfection time. To increase the value in increments:

Shortly press key  or key .

3. Scroll thru the values in 30 minutes steps:

Depress key  or key .

4. Store setting:

Shortly press key .

If the setting is not stored, the disinfection time will be reset to the original value after approx. 15 seconds.

Start UV-Disinfection

NOTE

Before disinfecting, remove the side cover of the UV lamp and refit it afterwards. Do not apply too much detergent to the UV lamp box. The residual current device can trip.

The UV disinfection can only be started if the front window is completely lowered (standby mode) and the work space illumination is switched off.

- Start routine:

Depress key  until ready signal sounds

The text **dis** and the remaining disinfection time in hours and minutes are displayed.

The LED of the UV-button is yellow illuminated.

At the end of the disinfection time, the time or operating hours will be displayed, depending on what has been previously selected.

Cancel UV-Disinfection

While the UV disinfection routine is run, it can be interrupted at any time.

1. Cancelling the routine:

- Shortly press key .

The yellow LED above key  goes off.

2. The display shows the current time or operating hours, depending on what was previously selected.

Rocker Switch

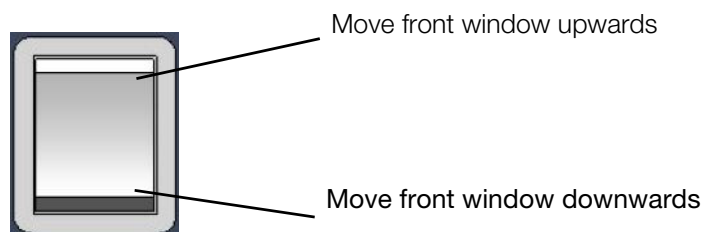



Figure 15 Rocker switch

With the rocker switch the front window can be moved upwards or downwards.

Moving the Front Window

The driving movement of the windshield is controlled by depressing the rocker switch, whose arrow symbol points in the direction of travel.

1. The driving movement of the windshield is controlled by depressing the rocker switch, whose arrow symbol points in the direction of travel.
2. To stop the movement upwards, release the rocker switch. Hold the rocker switch depressed at the bottom. To stop the travel movement down, release the rocker switch.
3. If the front window is not in working position:
 - The status indicator  is red illuminated.
 - The audible warning is switched off when the front window is completely closed.
4. If the front window reaches the working position, the driving movement is automatically stopped:
 - The status indicator  is green illuminated.
 - The audible warning is switched off.

Preparation

Hygiene Preparations for the Sample Chamber

The sample chamber surfaces and the accessories required for the work process must be disinfected and cleaned in accordance with the hygiene guidelines set forth for the application.

Preparing the Sample Chamber

Installing the accessories:

1. Lower the front window completely.
2. Open the front cover or move the front window into the maximum opening position.
3. Position the accessories in the working area of the workplate.
4. Close the front cover.
5. Move the front window to its working position and wait until the airflow has stabilized.



Operational safety!

The personal and material protection is ensured only if the airflow system of the device is working properly. If the alarm system issues failure messages when the front window is in the working position, stop all applications that may release harmful aerosols!

6. Then place samples into the chamber.
7. To interrupt the work process or for extensive experiment cycles without manual interference, switch the device to standby mode. When the working opening is completely closed, the safety cabinet is sealed aerosol-tight.

Response to Failure Messages

Failure messages are displayed on the display as outlined in the section Error messages at page 40. If one of these messages is displayed, contact the Technical Service immediately. To isolate the cause of the failure, the operating personnel must perform only the following tests and measures:

- Check to see if the exhaust air opening on top of the cabinet is blocked.
- Ensure that the on-site exhaust air system is activated.
- Close doors and windows in the laboratory to prevent drafts.
- Switch off devices in the vicinity of the safety cabinet that cause air turbulence or emit excessive heat.
- Open flames in the sample chamber may impair airflow conditions.

Work Rules

The observance of work rules ensures a minimum of operational safety when handling the safety cabinet.

Before starting an operation:

- Take off jewelry.
- Put on required personal protective gear, e.g. hand, face, or body protection.
- Clean and disinfect sample chamber surfaces at regular intervals.

During an operation:

- Place samples only within the defined work area of the workplate.
- Do not place unnecessary items into the sample chamber.
- Use only disinfected and cleaned accessories for the work process.
- Do not cause air turbulence, by quick hand, arm or body movement in the sample chamber or in front of the work opening.
- Do not place accessories into the sample chamber that cause air turbulence or emit excessive heat.
- Do not block air circulation at the ventilation slots of the workplate.

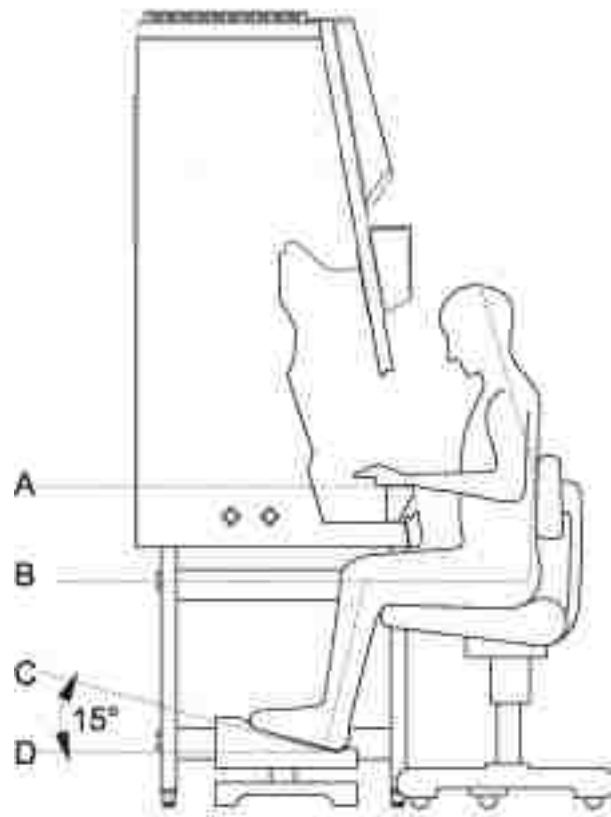
Sitting posture during work:**Figure 16** Sitting Posture

To prevent risks to health, a height-adjustable working chair with an adjustable seat back should be used during extended work periods at the safety cabinet.

- A** When the forearm rests on the armrest, it should be in an almost horizontal position.
- B** When the thigh is in a horizontal position, the angle between thigh and lower leg should exceed 90°.

To ensure a compensation between floor and sitting height, a footrest (DIN 4556) should be used. The minimal effective surface of the footrest should be 45 x 35 cm.

- C** The slope should be adjustable within a range of 5° to 15°.
- D** The adjustable height should extend to a minimum of 11 cm above the floor.

After finishing an operation:

- Remove samples from the sample chamber and store them properly.
- Clean and disinfect the sample chamber surfaces, including the workplate and the drain pan. Clean and disinfect all accessories.

Shut-down

Interrupting an Operation

To interrupt a work process, the blowers can be switched off.

1. Remove all samples from the safety cabinet and store them properly.
2. Remove accessories from the sample chamber and clean and disinfect them.
3. Clean and disinfect the sample chamber surfaces, the workplate, and the drain pan.
4. Switch the blowers off.

Shutting the Unit down

If the unit is not to be used or stored for an extended period of time, it must be completely decontaminated.



Decontamination measures!

To shut the device down, the sample chamber must be disinfected completely and the plenum, including the filters, must be sterilized using formaldehyde.

1. After the device has been decontaminated, close the front window completely.
2. Disconnect the device from the power supply system.

Cleaning and Decontamination

NOTE

Before cleaning and UV disinfection the covers of the UV lamps must be removed and afterwards installed.

Decontamination Procedure

Several procedures can be applied for decontaminating the safety cabinet. Which procedure is selected, depends on:

- the potential risk imminent in the agents,
- the degree of purity required by an experiment or by a work process.

Possible decontamination procedures:

Wipe/spray disinfection: is the standard disinfection procedure for cabinets used for microbiological experiments.

UV disinfection: is particularly suited as an intensifying additional disinfection after a wipe/spray disinfection.

Sterilization with steam: can be used for treating the removable stainless steel components. Examples of autoclavable components are the bezels of the UV lamps, the workplate or workplate segments and the armrests.

Disinfection with formaldehyde: can be performed if a sterile sample chamber is required for the work process. This sterilization procedure is mandatory:

- when filters are replaced,
- when the device is shut down,
- when the device is discarded.

Wipe/Spray Disinfection

The wipe/spray disinfection is performed in three stages:

- pre-disinfection,
- cleaning,
- final disinfection.

Recommended disinfectants:

NOTE Compatibility

Chloride-containing disinfectants may damage some surfaces; use only chloride-free disinfectants or a disinfectant with a low enough chloride content to have been proved harmless for stainless steel finishes! Disinfectants with an alcohol content of more than 70 % may cause embrittlement of plastic components after extended exposure. Use only disinfectants with a low alcohol content. When using a disinfectant with an alcohol content of more than 70 %, the release limit of 200 g within 2 hours must not be exceeded. Also suited are disinfectants based on quaternary ammonium compounds.

Predisinfection:

1. Remove all samples from the sample chamber and store them properly.
2. Remove accessories from the safety cabinet and disinfect them using the disinfection procedure recommended by the manufacturer.
3. The workplate and stainless steel components can be removed from the sample chamber and disinfected separately.
4. For predisinfection, spray disinfectant on all sample chamber surfaces or wipe the surfaces using disinfectant.
5. Do not remove the optional UV lamps from the sockets; wipe them thoroughly using a damp cloth.
6. Switch the device to work mode, move front window to the working position.
7. Allow disinfectant to react as recommended by manufacturer, then operate the safety cabinet for at least 15 to 20 minutes in the work mode so that released aerosols can be absorbed by the filters.

Cleaning:

1. Thoroughly remove dirt residues and deposits using a solution of tepid water and dishwashing agent.
2. Wipe the surfaces clean using a clean cloth and plenty of clear water.
3. Remove the cleaning liquid from the drain pan and wipe all sample chamber surfaces dry.

Final disinfection:

1. Again, spray disinfectant on all sample chamber surfaces or wipe the surfaces clean with disinfectant.
2. Allow disinfectant to react as recommended by manufacturer.

UV Disinfection after a Wipe/Spray Disinfection

An UV disinfection can be performed either by using the optional integral UV lamps. The run time of the routine can be preset with the operating panel.

NOTE

Before disinfection remove the UV side covers and replace them afterwards. Do not apply too much cleaning agent to the UV emitter box. The ground fault circuit interrupter may release.

UV Disinfection using the integral UV Lamps

Running the UV disinfection routine, see page 49.

Changing the UV Disinfection Time

Setting the run time for the UV disinfection, see page 48.

Disinfection with Formaldehyde

NOTE Disinfection procedure

Disinfection with formaldehyde bears considerable risks, the procedure must only be performed by specially trained authorized service personnel and in accordance to national regulations.

A suitable disinfection procedure must be selected according to the scope of application of the safety cabinet.

One possible method based on EN 12469/2000 is described below.

To cover the spectrum of action A, B, C and D, it is necessary to use another method. Based on recommendations of the RKI (Robert Koch Institute), another disinfection procedure is described in the service manual.

Procedure in accordance to EN 12469 / 2000:

For gas disinfection, formaldehyde is evaporated in the sample chamber of the completely sealed cabinet. The quantity of the formaldehyde used depends on the sample chamber volume of the cabinet version to be disinfected (see "Technical Data" on page 67). Per cubic meter of sample chamber volume, at least 5 g formaldehyde must be evaporated with 20 ml water (corresponds with 25 ml of a 20 % formaldehyde solution). The formaldehyde evaporates immediately when its boiling point is reached. The required reaction time is at least 6 hours.

After the required reaction time, the formaldehyde should be neutralized by evaporating a 25 % ammonium solution (10 ml per cubic meter of sample chamber volume).

NOTE

After the neutralization reaction time with ammonia, carry out check measurements and ventilate. Ventilation until the MAK value is reached: Formaldehyde concentration <0.3 ppm (Occupational Exposure Limits).

Ambient conditions and accessories:

The temperature at the cabinet location should be approx 21 °C, the relative humidity should be between 60 and 85 %. To evaporate the solution, a heating device with a container is required.

Cleaning the exterior Surfaces

Wipe the exterior surfaces of the device clean using a solution of tepid water and commercial dishwasher solution. Then, wipe exterior surfaces dry using a soft, clean cloth.

Cleaning the Front Window

For cleaning the front window (and for disinfecting it using wipe disinfection), the front window can be closed and hinged.

Cleaning the Drain Pan

Clean the drain pan using a solution of tepid water and commercial dishwasher.

1. Remove the working plates from the workspace.
2. Remove dirt residues and deposits thoroughly.
3. Wipe the drain pan clean using a clean cloth and plenty of clear water.
4. Remove the cleaning liquid from the drain pan and wipe the drain pan surfaces thoroughly clean.

NOTE Material residues

After cleaning, make sure that all cleaning materials have been removed completely from the drain pan.

5. Reinstall the working plates.

Replacing the inlet air protection

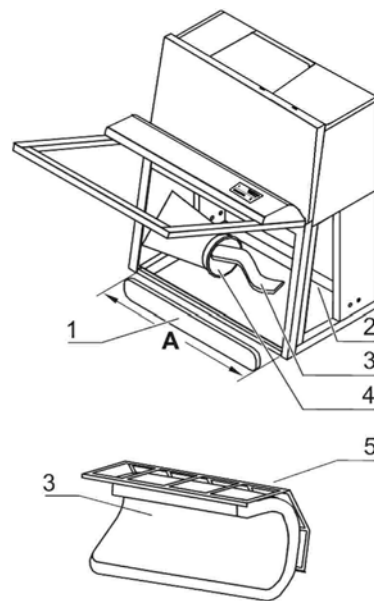

Figure 17 Inlet air protection

The coarse filter [3] is used as inlet protection for the airflow system. The coarse filter bracket is installed below the workplates in the floorpan at the rear panel of the work space [2].

To remove the coarse filter:

1. Remove the workplate(s) from the work space.
2. Have a suited disposal container [4] ready for the contaminated coarse filter.
3. Remove the coarse filter [3] from the bracket [5] and seal it airtight in the disposal container.

To install the coarse filter:

The coarse filter material is supplied by the meter and must be fit to match the width of the work space A.

4. Cut the coarse filter strip [1] to the required dimension.
5. Install the coarse filter into the bracket [5] and make sure that the filter material [3] covers the entire opening surface of the airflow system at the device backpanel.
6. Insert the workplate(s).

NOTE Inlet air protection

Do not operate the device without inlet air protection. Prior to any start-up of the device, make sure that the inlet air protection is installed!

Maintenance

Inspection

The annual inspection comprises the following checks:

- Electrical safety in accordance with national regulations.
- Functional test of the device.
- Checking all components for possible damage.
- Checking the filter state.

NOTE Perforated plate

The Perforated plate at the blanket of the sample chamber serves for the protection of the downflow filter and prevents refluxing. While scanning the filter surface for leak test the perforated plate must be built-in.

- Checking the airflow conditions.
- Repeat test in accordance with applicable standard (EN 12469:2000, NSF/ANSI 49 or other).

Service

HEPA filters:

As the filter replacement is an interference with the safety system of the device, filters must only be replaced by Thermo Electron LED or by adequately trained and authorized service personnel.

NOTE Filter change

Before filters are replaced the disinfection with formaldehyde is mandatory. After the filter replacement, a repeat test must be performed in accordance with applicable standard (EN 12469:2000 or other).

UV Lamps



Before replacing the UV lamps disconnect the unit from the power supply.

The UV lamps should be replaced after 8000 operating hours:

1. Remove cover from lamp housing. The cover is only pushed onto the lamp casing and may be pulled off easily.
2. Rotate the lamp in the socket so that the lamp contacts can be removed from the groove in the socket.
3. Insert the new lamp into the socket and rotate until the contacts engage.
4. Push the cover onto the lamp casing.

Sample Chamber Illumination

The tubes are installed in the front cover bezel.

1. Remove the bezel retaining screws and the bezel.
2. The tubes are retained by rotatable sockets. Rotate the tube carefully to the removal position and remove it from the socket.
3. Insert the replacement tube and rotate it to the working position.
4. Reinstall the bezel and secure it with the screws.

Replacing the Front Cover Seal

NOTE Front cover seal

**Check front cover seal in regular intervals, at least once a year.
If seal is damaged call Technical Support.**

Retrofitting and Repairs

External communication systems, e.g. failure report systems or components for supplying media such as gas solenoid valves can be retrofitted and integrated into the device control.

NOTE Repairs

All retrofitting and repair work are interferences with the safety system of the unit. Particularly modifications to the filter system and resulting changes of the airflow may impair personal and material protection. Such work must be carried out only by authorized service personnel.

Disposal

Disposal Procedure

Discarded cabinets or unit components contain reusable materials. All components with the exception of the HEPA filters can be disposed of after having been thoroughly decontaminated. The HEPA filters must be disposed of in accordance with the applicable national and state regulations for special solid waste.



Contamination hazard!

As the device can be used for processing and treating infectious substances, it may be contaminated. Prior to disposal, the complete device with filters must be decontaminated by performing a formaldehyde sterilization!



Recyclable materials!

Component	Material
Thermal insulation components	Polystyrene foam, EPS/PPS compound
Printed circuit boards	Enclosed electrical components coated with various plastics, mounted on epoxy resin-bound boards.
Plastic components, general	Note material labeling
Exterior housing	Steel, painted
Device backpanel	Stainless steel/steel, painted
Front cover seal	EMPP
Front window, side windows	Multi-layer safety glass
Operating panel and indicator foil	Polyethylene, Polyester
Workplates	Stainless steel
UV bezels	Stainless steel
Armrests	Stainless steel
Rechargeable battery (safety feature: Lower Front Window)	Nickel/metal hydrid

WEEE Conformity:

This product is required to comply with the European Union's Waste Electrical & Electronic Equipment (WEEE) Directive 2012/19/EU. It is marked with the following symbol:



Thermo Electron has contracted with one or more recycling/disposal companies in each EU Member State, and this product should be disposed of or recycled through them. Further information on Thermo Fisher Scientific's compliance with these Directives.

Technical Data

Dimensions					
Herasafe 2030i / Maxisafe 2030i		0.9	1.2	1.5	1.8
Exterior dimensions					
Width	mm/in	1000/39.4	1300/51.2	1600/63.0	1900/74.8
Depth	mm/in	800/31.5			
Height	mm/in	1552/61.1			
Interior dimensions					
Width	mm/in	900/35.4	1200/47.2	1500/59.1	1800/70.9
Depth	mm/in	627/24.7			
Height	mm/in	780/30.7			
Front window					
Working position	mm/in	200/7.9 + 250/9.8			
Max. opening	mm/in	780/ 30.7			
Working area height					
Seat position	mm/in	750/29.5			
Heightable	mm/in	750/29.5 - 950/37.4			
Stand height					
	mm/in	680/26.8 - 880/34.6			
Unit height with stand					
	mm/in	2216/87 / max. 2416/95			
Side wall feed throughs					
Diameter	mm/in	21.3/0.84			
Distance lower edge	mm/in	135/5.3			
Distance from the rear wall					
Bushing 1	mm/in	153.5/6			
Bushing 2	mm/in	243.5/9.6			

Electrical Data					
Herasafe 2025		0.9	1.2	1.5	1.8
Voltage					
Rated voltage	V	230V - 1/N/PE AC - 50/60 Hz			
Blower voltage	V	48 V / DC			
Current					
Power consumption	A	7.0	7.0	9.0	9.0
Leakage current IEC 1010, EN 61010	mA	< 3.5			
Motherboard fusing	A	2 x T15A H			
Outlet fusing	A	2x T 5 A			
On-site fusing	A	Circuit breaker B 16 / Fuse T 16 A			
Equipment fusing (230V)	A	2 x T16A H			
Power					
Power input max.	W	1675	1675	2010	2010
Protection					
Protection class		I			
Protection type		IP 20			
Overvoltage category (IEC 1010, EN 61010)		II			
Contamination degree (IEC 1010, EN 61010)		2			
Connection lines					
Connecting lines		cable (2.5 or 5 m/8.2 or 16.4 ft)			

Volume, weights and loads					
Herasafe 2025		0.9	1.2	1.5	1.8
Volume					
Device volume	m ³ /cf	1.1/39	1.4/49	1.7/60	2.1/74
Floorpan	l/cf	30/1	40/1.4	50/1.7	60/2.1

Weights					
Cabinet	kg/lbs	170/375	195/430	220/485	260/573
Stand AFS 1	kg/lbs	26/57	26/57	27/60	27/60
Stand AFS 2	kg/lbs	30/66	30/66	31/68	31/68
Loads					
Max. load per working area module	kg/lbs	25/55			
Max. load on overall working area	kg/lbs	50/110	75/165	75/165	75/165
Airflow system					
Herasafe 2025		0.9	1.2	1.5	1.8
Air speeds					
Inflow	m/s / fpm	0.45/88.6			
Downflow	m/s / fpm	0.32/63			
Air volume					
		0.9	1.2	1.5	1.8
Overall volume flow	m ³ /h / cfm	910/536	1215/715	1520/894	1824/1074
Downflow volume flow	m ³ /h / cfm	622/366	829/488	1037/610	1244/732
Inflow air volume flow	m ³ /h / cfm	288/170	386/227	483/284	580/341

Filter					
Herasafe 2025		0.9	1.2	1.5	1.8
Type		HEPA (H 14 acc. DIN EN 1822)			
Material		Glass fiber fleece			
Separability in MPPS	%	99.995			
Separability at 0.3 µm particle size	%	99.999			
Downflow					
Width	mm/in	915/36	1220/48	1525/60	1830/72
Depth	mm/in	457/18			
Height	mm/in	93/3.7			
Exhaust					
Width	mm/in	457/18	610/24		915/36
Depth	mm/in	457/18	457/18		457/18
Height	mm/in	117/4.6	117/4.6		117/4.6

Ambient conditions					
Herasafe 2025		0.9	1.2	1.5	1.8
Temperature					
Max. ambient temperature during operation	°C / °F	40/104			
Min. ambient temperature during operation	°C / °F	10/50			
Humidity					
Max. humidity/operation	% h.r.	90			
Max. humidity/storage	% h.r.	90			
Heat dissipation to environment					
200 mm/8" access opening					
Room temperature 20°C	kJ/s / BTU/hr	0.13/454	0.15/522	0.22/740	0.25/856
Room temperature rise					
Above room temperature with window closed	°K	< 2			
Ergonomics					
Noise level	dB(A)	57	57	57	57
		The noise level was determined in accordance with EN ISO 3744. The sound pressure level was measured at a distance of 1 m in front of the working opening. The measurement uncertainty is within a range of ± 2 dB.			

Certificate of Decontamination

Invoice recipient / Customer no.:				Location / Forwarding address:			
Year of manufacturer:	KC:	ST:	Name of technician:		Appointed date:		
order date:	Ordered by:		Order no.:				
Type of device:			ID no. / Order no.:		Operating hours:		
Equipment no.:	Factory no.:	Service device no.:	Date of delivery:	Date of start-up:	Customer inventory no.:		
Certificate of decontamination							
<p>Dear customer,</p> <p>when using biological and chemical agents within and outside of devices, hazards to the health of the operating personnel may be present and contamination of the surroundings of the device may occur when service or repair works are carried out. Within the scope of national and international legal regulations, such as</p> <ul style="list-style-type: none"> - responsibility of a company for the protection of its employees, - responsibility of the operator for the operational safety of devices, <p>all possible hazards must absolutely be prevented. Prior to any calibration, service, and repair works, prior to any relocation of a device, and prior to the shut-down of a device, the device must be decontaminated, disinfected, and cleaned as required by the work to be carried out. Therefore, we ask you to fill in this certificate of decontamination before you start with the required work.</p> <p>Yours sincerely</p> <p>Thermo Electron LED GmbH</p>							
Works to be carried out (please mark where applicable)							
Service	<input type="checkbox"/>	Filter replacement	<input type="checkbox"/>				
Repair	<input type="checkbox"/>	Relocation	<input type="checkbox"/>				
Calibration	<input type="checkbox"/>	Transport	<input type="checkbox"/>				
Declaration of possible contamination (please mark where applicable)							
The device is clear of biological material	<input type="checkbox"/>	The device is clear of dangerous chemical substances	<input type="checkbox"/>				
The device is clear of radioactivity	<input type="checkbox"/>	The device is clear of other dangerous substances	<input type="checkbox"/>				
The device is clear of cytostatic agents	<input type="checkbox"/>						
Certification:							
<p>Prior to carrying out the required work, we have decontaminated, disinfected, and cleaned the device as described in the operating instructions of the device and in accordance with nationally applicable regulations. The device does not present any hazards.</p>							
Note:							
Date, legally binding signature, stamp							

Find out more at [thermofisher.com](https://www.thermofisher.com)

thermoscientific